



Jockimo™
Advanced Architectural Products

Jockimo™

Advanced Architectural Products

UL Approved Anti-slip Glass Flooring

Jockimo is the only Underwriters Laboratories (UL) classified glass flooring product on the market. Our exclusive anti-slip GlassGrit™ and GlassFrit™ surfaces exceed ADA (Americans with Disabilities Act) requirements.

Jockimo is also the only glass flooring manufacturer that offers a monolithically polished edge on their fully tempered glass stair treads and flooring. Others may offer polishing but their glass is annealed and in our opinion not as safe.

Jockimo is the first and only to offer a scratch resistant walking surface. Jockimo also offers an ADA required contrasting strip on the nosing of stair treads and landings if required.

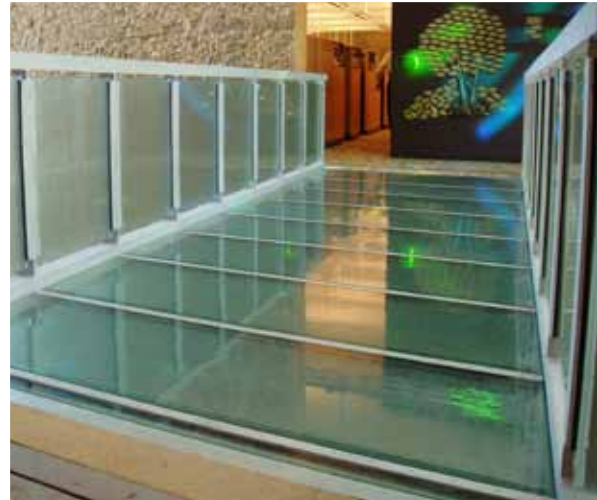

Anti-slip Glass Flooring





Crystal Clear™



Ultimate Privacy S-Revo™



Ultimate Privacy Frost™

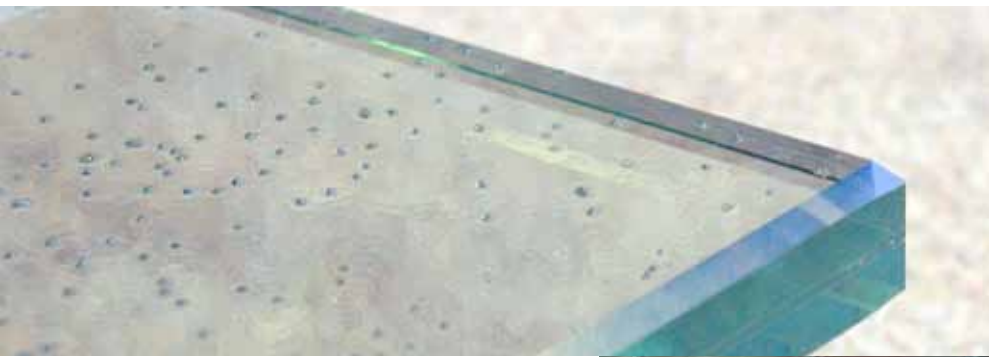

Jockimo, Inc.

Phone: 949.251.0075

Fax: 949.251.0126

www.Jockimo.com





Jockimo, Inc.

Phone: 949.251.0075

Fax: 949.251.0126

www.Jockimo.com





Jockimo, Inc.

Phone: 949.251.0075

Fax: 949.251.0126

www.Jockimo.com

Anti-slip Glass Flooring

Jockimo™
Advanced Architectural Products





Jockimo, Inc.
Phone: 949.251.1560
Fax: 949.251.0126
www.Jockimo.com





Jockimo, Inc.
Phone: 949.251.1560
Fax: 949.251.0126
www.Jockimo.com

Anti-slip Glass Flooring

Jockimo™
Advanced Architectural Products



Jockimo, Inc.
Phone: 949.251.1560
Fax: 949.251.0126
www.Jockimo.com



Jockimo™

Advanced Architectural Products

UL Approved Anti-slip Glass Treads

Jockimo is the Only Underwriters Laboratories (UL) tested and approved glass flooring product on the market. Our exclusive anti-slip Classic GlassGrit™ surface exceeds ADA (Americans with Disabilities Act) requirements.

Jockimo is also the only glass flooring manufacturer that offers a monolithically polished edge on their fully tempered glass stair treads and flooring. Others may offer polishing but their glass is annealed and in our opinion not safe.

Jockimo offers an ADA (Americans with Disabilities Act) required contrasting strip on the nosing of stair treads and landings if required. Jockimo is the only glass flooring manufacturer that can offer this Jockimo patent pending product.

Anti-slip Glass Treads



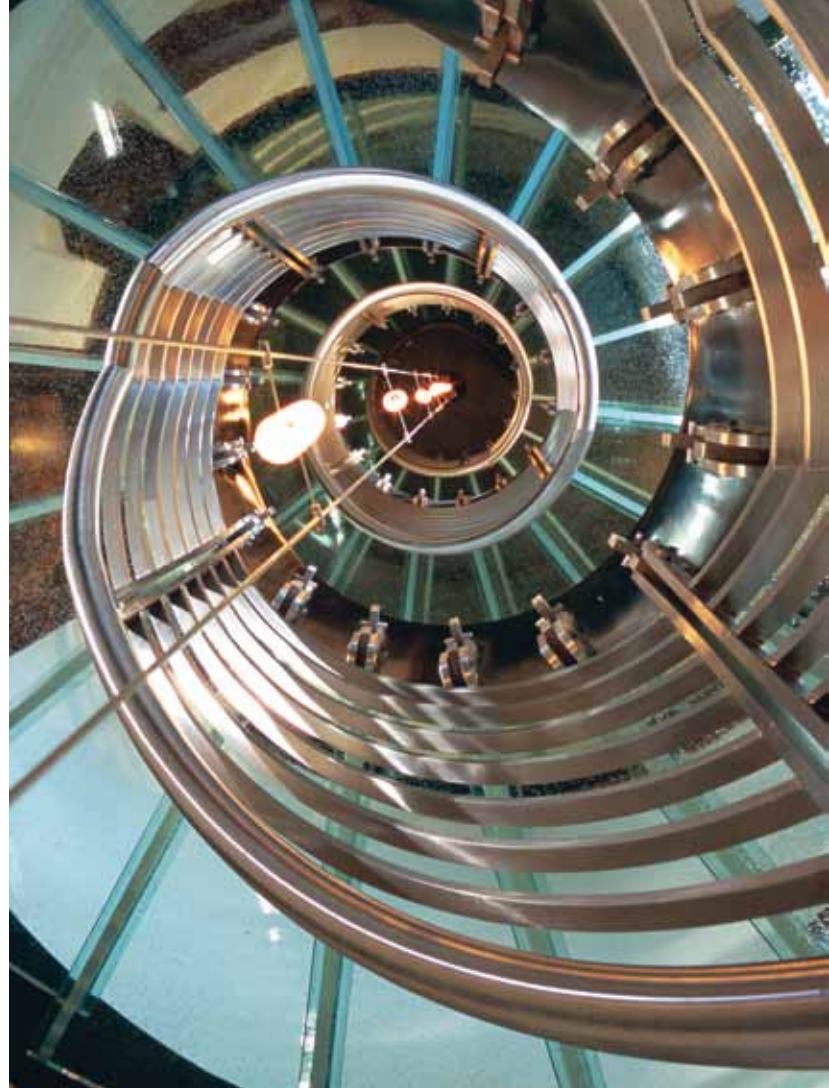

Jockimo, Inc.
Phone: 949.251.0075
Fax: 949.251.0126
www.Jockimo.com



Crystal Clear™



Ultimate Privacy S-Revo™



Ultimate Privacy Frost™

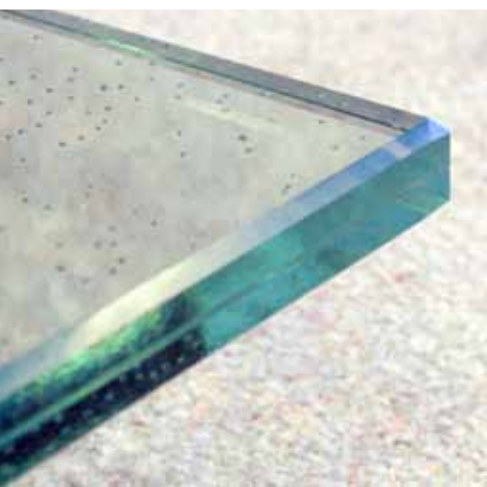

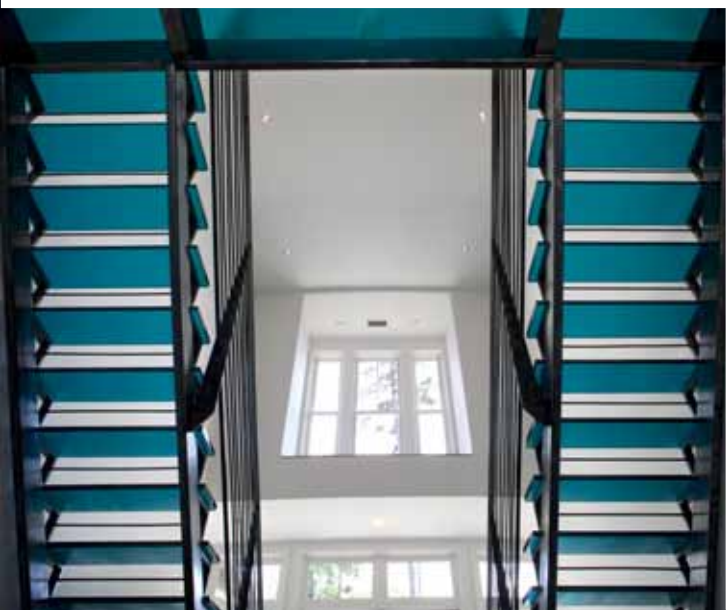



Jockimo, Inc.

Phone: 949.251.0075

Fax: 949.251.0126

www.Jockimo.com



Jockimo, Inc.

Phone: 949.251.0075

Fax: 949.251.0126

www.Jockimo.com



Jockimo, Inc.

Phone: 949.251.0075

Fax: 949.251.0126

www.Jockimo.com

Jockimo™

Advanced Architectural Products

Structural Support Methods

There are numerous options available to safely support glass flooring panels. Each project is different and in turn each project requires proper review to ensure safety. Our preferred support system is four-sided because of the high safety level involved — but this does not mean other options are not safe.

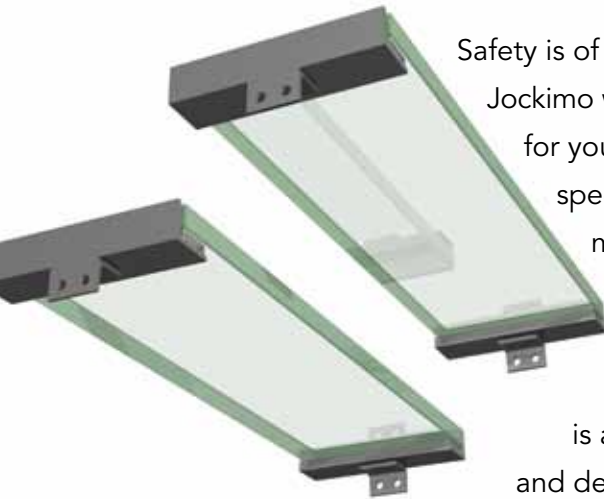

Safety is of the utmost importance and at Jockimo we engineer the glass specifically for your project with your project's specifications. Jockimo is the only manufacturer that will provide you with an engineering analysis pdf of your glass project from our structural engineer — who is a glass specialist. (Engineering and design services available.)

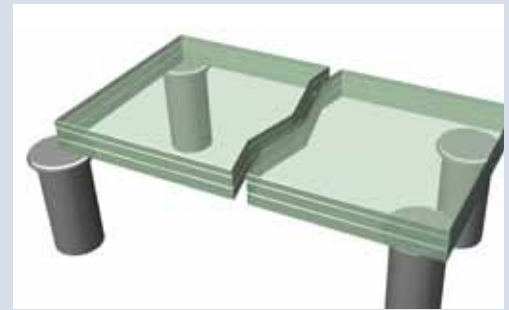
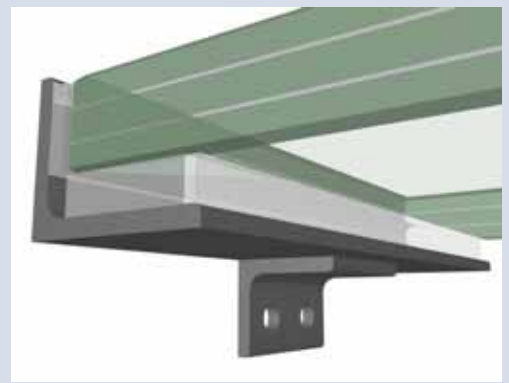

Technical Data

Sizes available: Each project is manufactured per the project specifications — in turn, all panels are custom made. (Standard sizes available.)

Thickness: Thickness and make-up varies by project. Once we review your project we can suggest a make-up for you. (The standard make-up is 3 lites of 3/8" glass for a total thickness of approx. 1-1/4".)

Product type: Laminated fully tempered glass is utilized for strength. Per the new ASTM code, all glass flooring products — both panels and treads — have to be made out of a minimum of 3 pieces of glass per panel.

Structural Support

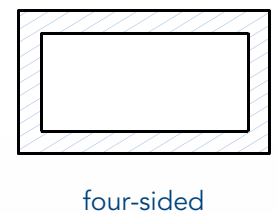
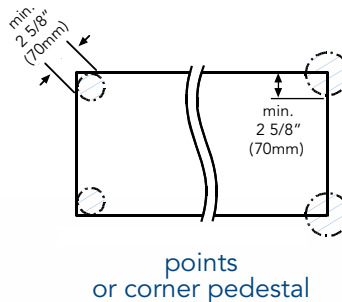
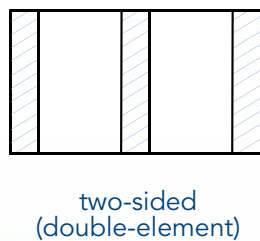
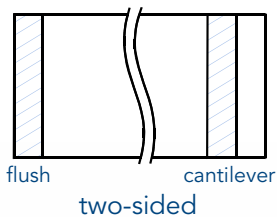

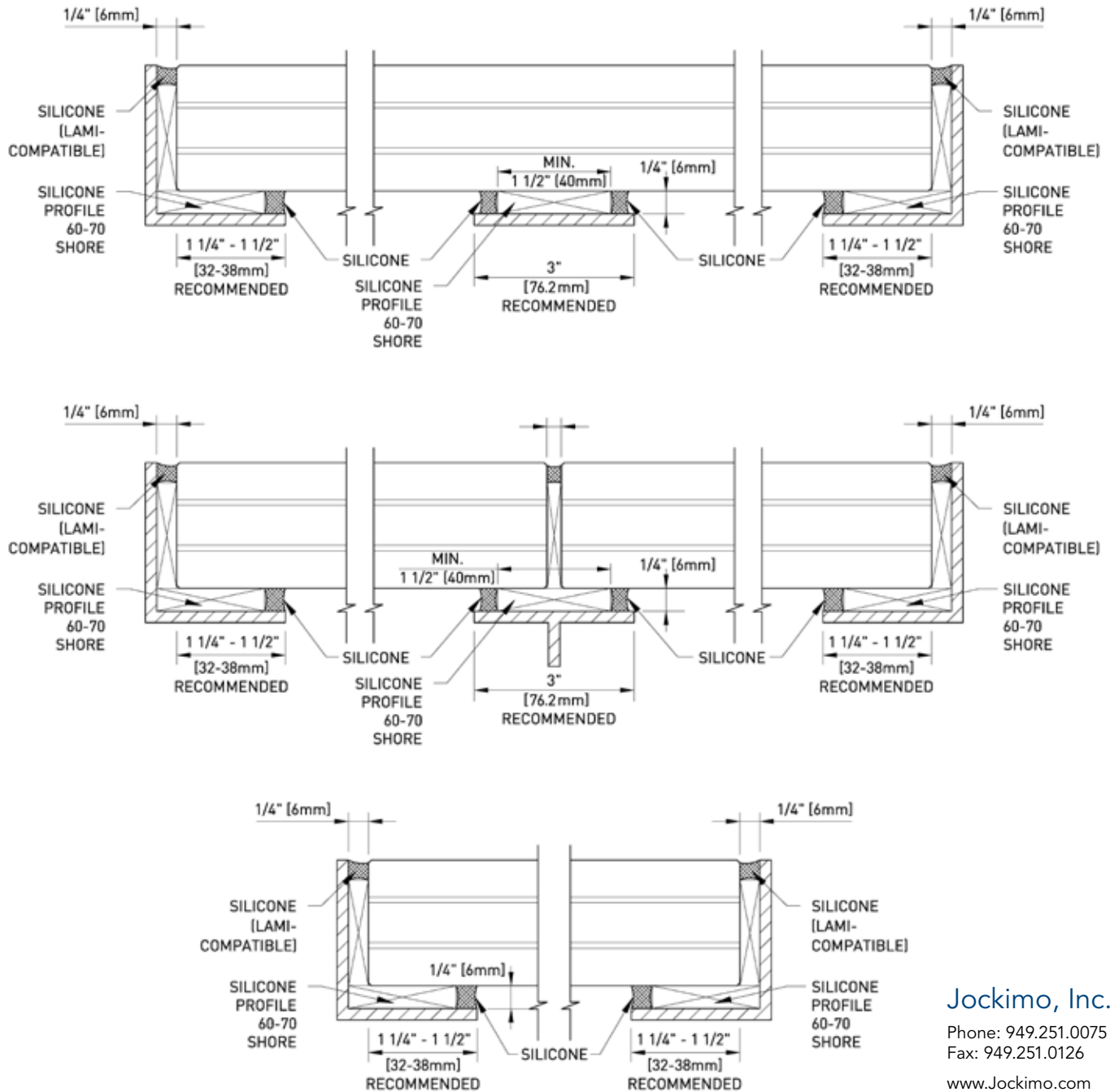

Jockimo, Inc.

Phone: 949.251.0075

Fax: 949.251.0126

www.Jockimo.com

The silicone setting strips should be glued to the steel substructure before the glass is set. The silicone we recommend is a non-acidic clear silicone. Here is a list that we have tested as being safe and recommended:

- Dow Corning 995
- GE SCS 2800

* Please note—using any non-recommended silicone will void the glass warranty.

The silicone setting blocks should be 60–70 shore. Various products can be used. CR Laurence has a product called PSB 250 which are 1/4" x various lengths. CR Laurence 1-800-421-6144. Other products will work as well.

There are two different ways to install setting blocks: 1.) Place a block every 6" – 12" around the perimeter of the support. 2.) Use a rubber/neoprene material that fully covers the support. The material can be cut to size and set in place.

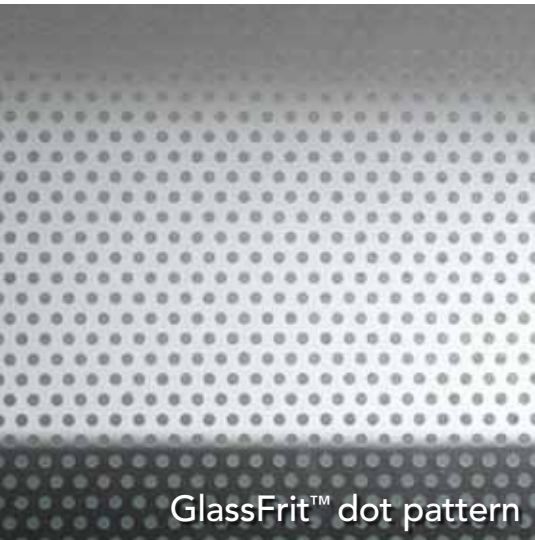

GlassFrit™ dot pattern



GlassGrit™



GlassGrit™ with Privacy Frost

Flooring Surfaces

Jockimo is the only Underwriters Laboratories (UL) classified anti-slip glass flooring product on the market. Both of our exclusive anti-slip walking surfaces—GlassGrit™ & GlassFrit™—exceeds ADA (Americans with Disabilities Act) requirements.

GlassFrit™ full coverage

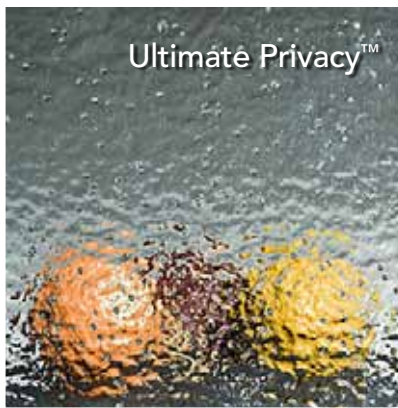

MULTIPLE OPTIONS AVAILABLE.

Available in Ultimate Privacy™, Crystal Clear™, Privacy Frost™, or Ultimate Privacy Frost™ in either our GlassGrit™ or GlassFrit™ anti-slip walking surfaces. Other options include glass colors, lamination colors, paint, custom frost, special lamination interlayers as well as custom textures.

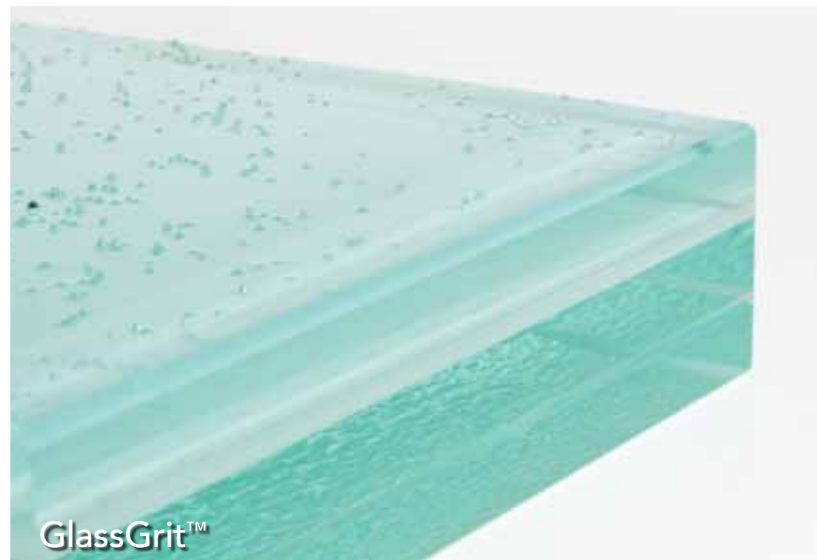
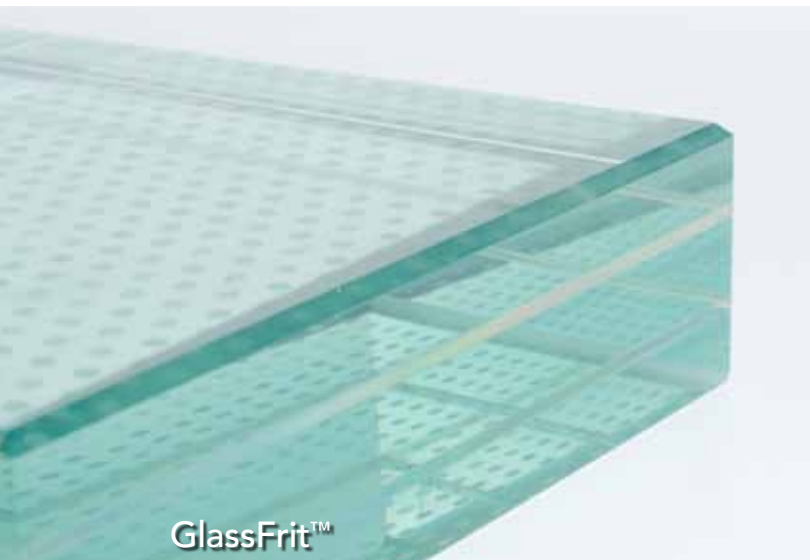

Jockimo, Inc.

Phone: 949.251.0075

Fax: 949.251.0126

www.Jockimo.com

MONOLITHICALLY POLISHED EDGES.

Jockimo is the only glass flooring manufacturer that offers a monolithically polished edge on their fully tempered glass stair treads and flooring after laminating. Others may offer polishing but their glass is annealed and in our opinion, not as safe as fully tempered glass.

SCRATCH RESISTANT WALKING SURFACE

Jockimo is the first and only manufacturer to offer a permanent scratch resistant coating on the walking surface of their glass flooring.